

Surge Arrester Installation Instructions

⚠ CAUTION

This equipment should be installed only by personal properly trained with the safety practices required for working with medium voltage electrical equipment.

⚠ WARNING

Prior to installing this product please check the name plate information of arrester stamp on the top plate to verify is the correct product for the application.

Also verify if surge arrester is broken or missing pieces. Do not install a damaged arrester.

NAMEPLATE INFORMATION

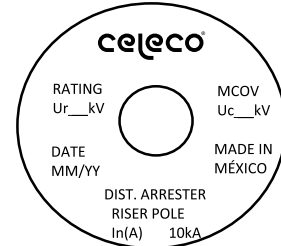

Note: Nameplate information is for reference only, it may vary depending on the application or region.

INTRODUCTION

Arresters are protection devices designed to limit overvoltage transient waves caused by a temporary current discharge. Celeco[®] arresters are manufactured in Monterrey, Mexico with the highest quality components according to IEC60099-4 & IEEE62.11, and for safety with a non-fragmenting design.

The outer metal parts of the surge arrester are designed to prevent damage caused by the environment such as oxidations and mounting accessories are hot dip galvanized to avoid corrosion caused by the most extreme atmospheric conditions.

Each surge arrester is inspected and tested in the factory, once you receive the surge arrester, please review the product thoroughly for damage or loss of parts during shipment.

INSTALLATION

Standard configurations

These instructions are not intended to cover all details or variations in safety, equipment, procedures or process described nor to provide for every possible contingency to be met in connection with installation, operation or maintenance.

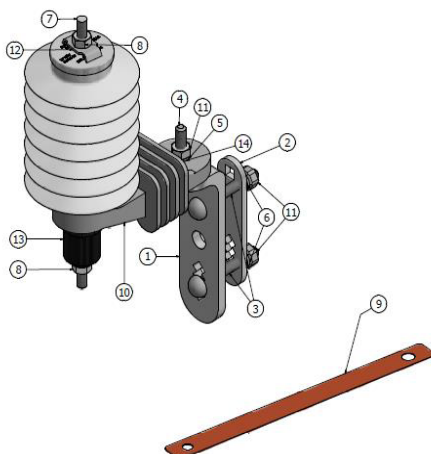
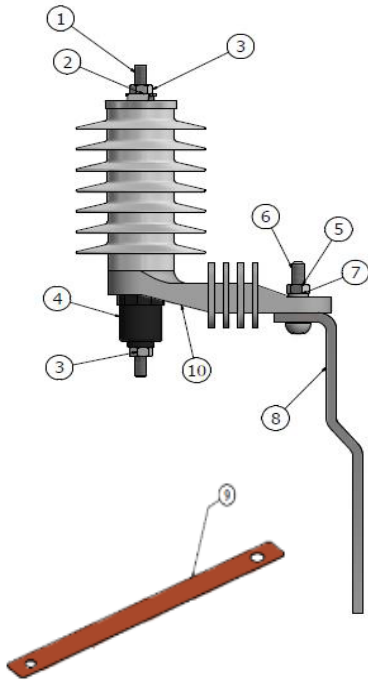

Figure No.1 Nema cross-arm bracket configuration.

Installation of Nema cross-arm bracket configuration arrester (Figure No.1):

1. NEMA hanger "L" bracket
2. Back strap
3. Two round head screws 3/8 x 5 in.
4. One round head screw of 3/8 x 2 1/4 in
5. Lock washer 3/8 in
6. Two flat washers 3/8 in
7. Bolt terminal 3/8 in
8. Two stainless steel nuts 3/8 in
9. Copper ground strap
10. Insulating arrester hanger
11. Three hex nuts of 3/8 in
12. Line connector (mechanical clamp)
13. Ground Lead Disconnecter
14. Flat washer 1.37 in

Installation Transformer bracket configuration (figure No.2):



1. Bolt terminal 3/8 in
2. Line connector (mechanical clamp)
3. Two stainless steel nuts 3/8 in
4. Ground Lead Disconnecter
5. Hex nuts of 1/2 in
6. One round head screws of 1/2 x 2 in
7. Lock washer 1/2 in
8. Transformer bracket
9. Copper ground strap
10. Insulating arrester hanger

15. Ground lead cable (figure No. 3) is optional.

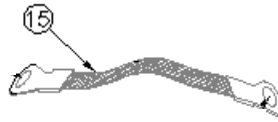

NOTE: If you do not see a hardware configuration or you have a special request for your intended application please contact any of our representatives.

Figure No. 2 Transformer bracket configuration.

Figure No.3 Ground lead cable.

NEMA HANGER ARRESTER INSTALLATION

1. Install bracket (1) and back strap (2) in the cross arm using the screws (3), the washer (6) and the nuts (13) as shown in the figure.
2. Place insulated hanger (10) using the screw (4), the lock washer (5), the nut (11) and the flat washer (14) as shown in the figure, the recommended installation torque for both line terminal and ground connection is 20 lb-ft.

TRANSFORMER MOUNT ARRESTER INSTALLATION

1. Install bracket (8) in the transformer as shown in the figure.
2. Place insulated hanger (10) using the screw (6), the lock washer (7), the nut (5) as shown in the figure, the recommended installation torque for both line terminal and ground connection is 20 lb-ft.

RECOMMENDATIONS

For the best protection, keep the line and ground lead short and mount the arresters as close as possible to the protected equipment.

The arrester line terminal can accept conductor sizes AWG No 6 solid to through AWG 2/0 stranded.